

PSB

Installation and Operation

Connection and Remote End Termination
for PSB Type 27-1680-..10/.... heating system

1. Product description

The PSB type 27-1680-...10/.... Ex heating system with the PSB (type 07-5801....) self-limiting parallel heating tape, assembled with a connection and remote end termination system (installation kit 05-0091-0130 and/or 05-0091-0136) in cold connection technology, is set up as a stationary resistance heating system for pipelines or containers in hazardous areas. It is used in Zones 1, 2 or Zone 21 according to the certified explosion group II and temperature classes T5/T6.

After assembly the supply wires and the twisted protective braid of the heating tape are always connected to terminals in an enclosure with „increased safety“ protection class (in conformance to the relevant standards EN 60079-0 and EN 60079-7).

2. Technical data

Rated voltage
110 to 120 V or 208 to 254 V

Rated current
max. 32 A

Referenced rated capacity
max. 33 W/m at 10°C

Explosion protection

Ex protection type

 II 2G Ex e II T5, T6

 II 2D Ex tD A21 IP65 T 95 °C, T 80 °C

Certification

KEMA 08 ATEX 0111

Conformity to standards:

EN 60079-0: 2006, EN 60079-7: 2007, EN 60079-30-1: 2007, EN 61241-0: 2006, EN 61241-1: 2004

Minimum bending radius
25 mm

Max. permissible process temperature

(applies to heating tape with remote end termination)
+65°C when the heating tape is switched on
+80°C when the heating tape is switched off
cumulative 1,000 h

Ambient temperature range
-50°C to +55°C

Min. cut-in temperature
-40 °C

3. Safety Instructions

The relevant installation and operating regulations must be observed for electrical systems in hazardous areas (e.g. Directive 1999/92/EC, Directive 94/9EC, EN 60079-14, EN 61241-14 and the DIN VDE 0100 series).

The requirements under EN 60519-1 and EN 60519-2 must be adhered to.

Thermal Safety Class 0 under EN 60519-2 Section 13 is met by the heating tape's design characteristics.

The Cu braid with a resistance of < 18.2 Ω/Km is suitable as a protective conductor.

To protect against indirect contact, conductive parts from other firms must be included in the (protective conductor) safety measures. For each electric circuit it is necessary to have a residual-current circuit-breaker and a means of isolating all other wires from the current supply.

The operator of an electrical system in a hazardous environment has to keep the equipment in an orderly condition, operate it correctly, monitor it and do the required maintenance and repairs.

(EN 60079-14, EN 60079-17, EN 60079-19 and EN 61241-14).

4. Assembly of heating circuits

The specifications in the EC Type Examination Certificate and in the installation instructions must be observed. The data in Installation Instruction for the heating tape must be observed also.

Do not connect the heating tape's two supply wires – short circuit!

5.a) Assembly

The relevant installation and operating regulations must be observed when setting up or operating explosion-protected systems (e.g. EN60079-14, EN 60079-30-2 and the DIN VDE 0100 series).

The heating tape must be installed on the workpiece in accordance with the project engineering specifications. Only qualified specialists may do any of the work on the machine. Before any work is done on the machine, it must have come to a complete stop, be disconnected and precautions must be taken to ensure that it cannot be switched on again.

Before and during installation: keep the ends and connection components of the heating system dry. The metallic braiding in this heating system must be connected to a suitable earthing terminal.

!! The bending radius may not be less than the minimum of 25 mm and the heating tape may not be bent on its narrow side.

The heating tape is attached to the workpiece by means of temperature-resistant adhesive tape with a max. spacing of 200 mm!! Use only plasticiser-free adhesive tapes (no PVC adhesive tapes)!

To ensure efficient heat transmission, the heating tape must have even contact over the entire length of the surface. If necessary, the distances between fastenings must be reduced. The tape is laid on

Reservation

Technical data subject to change without notice. Changes, errors and misprints may not be used as a basis for any claim for damages. 1

the pipelines either parallel to the axis of the pipe or in spiral form (in accordance with the project engineering instructions).

On plastic pipes, which conduct heat less efficiently than metal pipes do, aluminium foil or aluminium adhesive tape is put under or over the heating tape. This substantially improves the distribution of heat, prevents a local accumulation of heat and at the same time it partly compensates for the lower heat dissipation and associated reduction in the capacity of the heating tape.

Once the heating system with accessories has been mounted, the insulation resistance between the heating conductor and the metallic braid must be verified.

The testing voltage should be at least 500VDC and the insulation resistance at least 20 M Ω /km EN 60079-30-2 Section 8.3.4)

When used in TT and TN systems a residual current device according to IEC 60079-30-1, clause 4.3 point d) shall be installed. When used in IT systems an insulation monitoring device according to IEC 60079-30-1, clause 4.3 point e) shall be used.

5.b) Commissioning

The equipment may only be operated if it is clean and free of any damage.

Electrical systems must be examined by an electrician before commissioning and afterwards at certain intervals of time.

6. Operation, maintenance and fault clearance

The heating systems must be used only in accordance with their intended purpose and within the operating data specified by BARTEC.

The operator of an electrical system in a hazardous environment must keep it in good condition, operate it properly, monitor it and do maintenance and repairs. (EN 60079-14, 61241-14).

Only an electrician may do the maintenance work and fault clearance.

Before restarting operation, check compliance with the applicable laws and directives. Before maintenance or troubleshooting, make sure that the specified safety regulations are adhered to.

7. Accessories, spare parts see BARTEC catalogue.

Maximum length of heating circuit (according to the dimensioning of the capacity circuit breaker, characteristic C)

Type	°C	W/m	Operating voltage AC 120 V			Operating voltage AC 240 V		
			16 A	20 A	32 A	16 A	20 A	32 A
			m	m	m	m	m	m
PSB 10 07-5801-.10.	+10		95	95	95	205	205	195
	-15	10	69	90	95	139	186	195
	-30		58	75	95	120	150	195
PSB 13 07-5801-.13.	+10		78	86	86	169	179	174
	-15	13	55	72	86	111	149	174
	-30		47	59	86	94	124	174
PSB 15 07-5801-.15.	+10		67	80	80	145	162	160
	-15	15	45	60	80	93	125	160
	-30		39	49	80	77	106	160
PSB 20 07-5801-.20.	+10		58	70	70	116	140	140
	-15	20	37	46	70	72	93	140
	-30		30	38	61	55	77	110
PSB 25 07-5801-.25.	+10		43	58	63	88	117	126
	-15	25	30	38	55	58	75	117
	-30		26	31	53	45	64	100
PSB 33 07-5801-.33.	+10		33	45	54	70	90	108
	-15	33	25	32	45	49	64	95
	-30		21	26	43	43	52	82

8. Type label heating system

The type label is to be filled in manually on the basis of the table and points 1-6. The blanks in the heating system's type number must be filled on the basis of the components used. A water-proof and lightfast marker must be used (e.g.: Staedtler Lumocolor permanent special marker or BARTEC no.: 02-7140-0001).

The serial no.: and the TAG no. can be filled in by the person setting up the heating-circuit.

A practical example of a filled-in type label is given further on. The type label must be stuck onto the lid of the junction box. The surface must be cleaned first before the glue is applied. Care must be taken that the sticker is put on carefully. It may not jut out over the correct area and it may not have any air bubbles.

CE 0044	PSB Heating system	BARTEC D - 97960 Bad Mergentheim
	Type 27-1680 -	0
KEMA 08 ATEX 0111		
II 2G Ex e II T ①		1 - cold-applied Ta -50°C to +55°C
II 2D Ex tD A21 IP65 T ② °C		1 - PA box 27-5452-4***J**** 2 - AL box 27-5452-5***J**** 3 - SS box 27-5452-6***J**** 9 - custom. box
Protective device ③ A		0 - 110V to 120V 1 - 208V to 254V
Breaker size max. 32 A		
Supply voltage ④ V		
Frequency ⑤ Hz	Serial no.:	
Construction __/__/⑥ __ week/year	TAG no.:	

Practical example:

The following components were used:
PSB 120 V 26 W; Cold-applied connection technology and BARTEC polyester junction box.
It was filled in according to the grey-shaded line in the table.

CE 0044	PSB Heating system	BARTEC D - 97960 Bad Mergentheim
	Type 27-1680 -	0 1 1 0
KEMA 08 ATEX 0111		
II 2G Ex e II T ⑤		1 - cold-applied Ta -50°C to +55°C
II 2D Ex tD A21 IP65 T ② °C		1 - PA box 27-5452-4***J**** 2 - AL box 27-5452-5***J**** 3 - SS box 27-5452-6***J**** 9 - custom. box
Protective device 20 A		0 - 110V to 120V 1 - 208V to 254V
Breaker size max. 32 A		
Supply voltage 120 V	Serial no.:	123456/09
Frequency 50 Hz	Construction	15/2009 week/year TAG no.:
Construction __/__/⑥ __ week/year		

Table

Typ heat trace	Supply voltage	Supply voltage ④	T-class ①	Temp.
07-5801-110 *	120 V	impressed voltage	T5	T95 °C
07-5801-113 *	120 V		T5	T95 °C
07-5801-115 *	120 V		T5	T95 °C
07-5801-126 *	120 V		T5	T95 °C
07-5801-133 *	120 V		T5	T95 °C
07-5801-210 *	254 V		T6	T80 °C
07-5801-213 *	254 V		T6	T80 °C
07-5801-215 *	254 V		T6	T80 °C
07-5801-226 *	254 V		T5	T95 °C
07-5801-233 *	254 V		T5	T95 °C

③ Protection device: 16 A, 20 A, 32 A

⑤ Frequency: 50 oder 60 Hz

⑥ Construction week/year: 15/2009 (for example)

Reservation

Technical data subject to change without notice. Changes, errors and misprints may not be used as a basis for any claim for damages.

8. Non-BARTEC enclosure

If an enclosure from another company is used, all requirements specified in the checklist must be fulfilled.

The enclosure material is limited to the selection indicated.

The external dimensions of the enclosure must conform to the specified minimum dimensions.

Certification of „e“ increased safety type of protection in compliance with EN 60079-7 must be presented for all components.

Requirements set for non-BARTEC enclosures

Material

Polyester

Aluminium

Stainless steel

External dimensions of the enclosure

1 heating circuit at least 122 x 120 x 90mm

1 to 3 heating circuits at least 220 x 120 x 90mm

Ambient temperature -50 °C up to +55° C

Protection class (EN 61241-0) at least IP 65

Requirements set for connecting terminals

Rated cross-section 6 mm²

Working temperature -50 °C up to +80 °C

Minimum distance between conducting terminals and enclosure wall 25 mm

Requirements set for the cable gland

Working temperature -50 °C up to +70 °C

Erklärung der Konformität
Declaration of Conformity
Attestation de conformité

N^o 21-1680-7C0001

BARTEC

BARTEC GmbH
Max-Eyth-Straße 16
97980 Bad Mergentheim
Germany

Wir

We

Nous

BARTEC GmbH,

erklären in alleiniger Verantwortung, dass das Produkt

declare under our sole responsibility that the product

attestons sous notre seule responsabilité que le produit



PSB Heizsystem

PSB heating system

PSB système de chauffage

Typ 27-1680-10/******

auf das sich diese Erklärung bezieht den Anforderungen der folgenden Richtlinien (RL) entspricht

to which this declaration relates is in accordance with the provision of the following directives (D)

se référant à cette attestation correspond aux dispositions des directives (D) suivantes

ATEX-Richtlinie 94/9/EG

ATEX-Directive 94/9/EC

ATEX-Directive 94/9/CE

und mit folgenden Normen oder normativen Dokumenten übereinstimmt

and is in conformity with the following standards or other normative documents

et est conforme aux normes ou documents normatifs ci-dessous

**EN 60079-0:2006
EN 61241-0:2006**

**EN 60079-7:2007
EN 61241-1:2004**

EN 60079-30-1:2007

Kennzeichnung

Marking

Marquage

**II 2 G Ex e II T5, T6
II 2 D Ex tD A21 IP65 T95°C, T80°C**

Verfahren der EG-Baumusterprüfung

Procedure of Ex-Type Examination

Procédure d'examen CE de type

KEMA 08 ATEX 0111

CE 0044

Bad Mergentheim, den 29.09.2009

ppa. Ewald Warmuth
Geschäftsleitung / General Manager

Installation kit 05-0091-0129/05-0091-0135

a

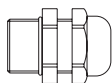

b

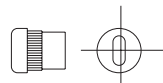

c

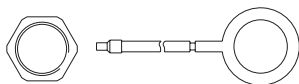

d



e

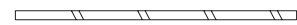

f



g



h



Connection

The dimensions specified in the installation instructions must be strictly observed!

Cut the heating tape with a straight cut.

Push on the cap for screw connection **a** and sealing **b**.

Remove 145 mm of the protective outer sheath from the heating tape.

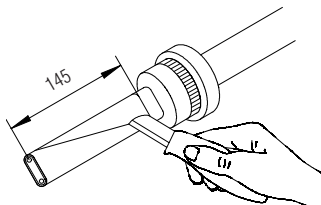

1

Push the protective braid back (1). Use the screwdriver to form an eyelet (2). Be careful not to damage the internal insulation.

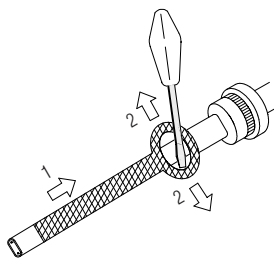

2

Pull the heating tape out of the protective braid (3).

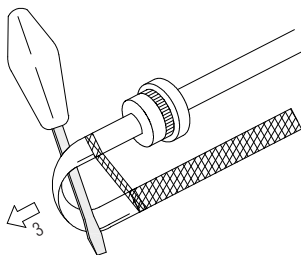

3

Self-limiting parallel heating cable

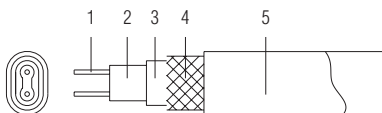

- 1 wire
- 2 heating element
- 3 insulating jacket
- 4 metal braid covering
- 5 protective outer sheath

Twist the metal braid covering.

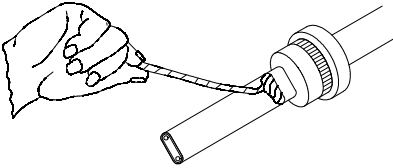

4

Pull the strands out and twist them. Remove the remaining heating element. (Fig. 7 and 8)

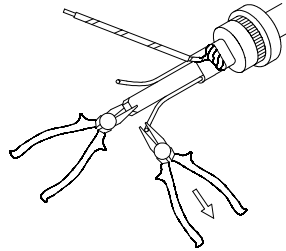

7

Push the green/yellow heat shrinkable tubing **e** (120 mm) onto the twisted metal braid covering. Make an incision into the insulating jacket at a point 115 mm from the beginning of the heating tape and remove that amount.

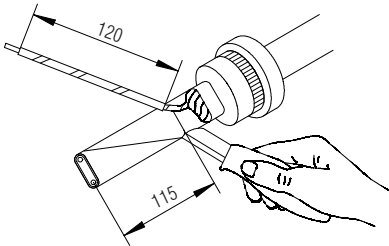

5

Cut out a triangle (5 mm) between the strands. Put some silicone adhesive **h** onto the exposed heating element, the insulating jacket and into the silicone hose. Push the silicone hose **d** over the exposed wire and the insulating jacket. Push the sealing **b** directly up to the silicone hose.

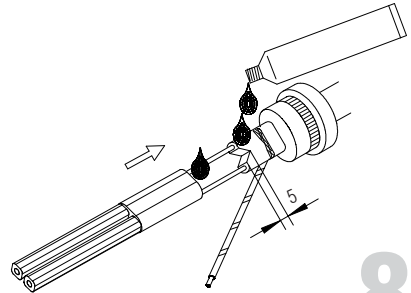

8

Make an incision into the edges of the heating element.

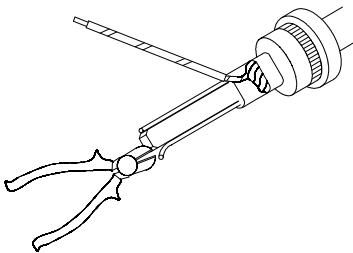

6

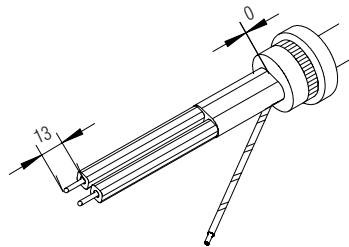

9

Reservation

Technical data subject to change without notice. Changes, errors and misprints may not be used as a basis for any claim for damages.

Screw the screw connection body **a** in the enclosure. Push the grounding strap **c** over the thread and secure it with a nut **b**. Connect the green/yellow core wire of the grounding strap to the PE. Connect the heating tape in the junction box to L, N and PE, insert the heating tape with the pushed-on sealing into the screw connection body and tighten the screw cap. The grounding strap **c** is not needed for stainless steel or aluminium enclosures.

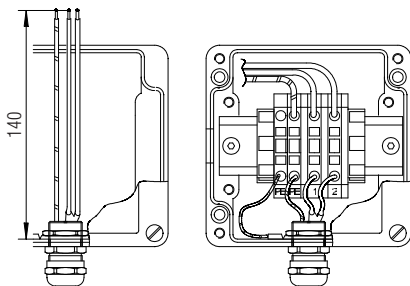

10

Cut off the heating tape with a straight cut. Remove 7 mm from the protective outer sheath on the heating tape.

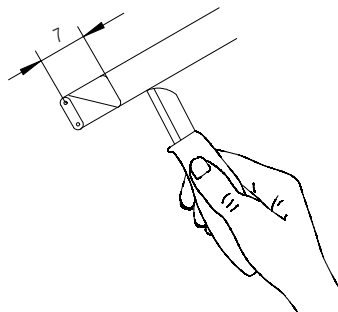

11

Remote end termination

Take the metal braid covering off the end of the heating cable. Make sure that the internal insulation is not damaged. Cut out a triangle (5 mm) between the strands.

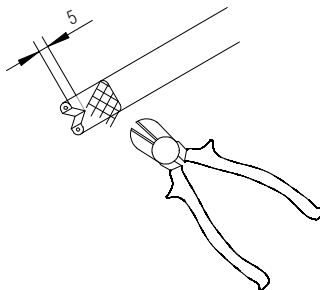

12

Put silicone adhesive **h** into the end cap **g** and onto the exposed insulating jacket. Push the end cap over the end of the heating tape until some of the adhesive oozes out.

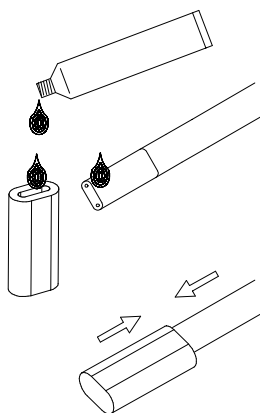

13

BARTEC GmbH
Germany

Max-Eyth-Straße 16
97980 Bad Mergentheim

Phone: +49 7931 597-0
Fax: +49 7931 597-494

info@bartec.de
www.bartec-group.com