

PSB PLEXO P**Installation and Operation**

Connection and Remote End Termination
for PSB Type 27-1680-..20/.... heating system
and PSB Type 27-1680-..30/.... heating system

21-1680-7D0003-12/09-BEH-D294619

1. Product description

The PSB heating system type 27-1680 ** 20 **** with the PSB (type 07-5801 *** A) self-limiting parallel heating tape, assembled with a connection and remote end termination or joining system with PLEXO P, the PSB heating system type 27-1680 ** 30 **** with the PSB (type 07-5801 ****) self-limiting parallel heating tape and assembled with a connection and remote end termination or joining system with PLEXO P and cold connection technology (installation kit 05-0091-0130 and/or 05-0091-0136), is set up as a stationary resistance heating system for pipelines or tanks in hazardous areas. It is used in Zones 1, 2 or 21 in accordance with the certified explosion group II and temperature classes T5, T6.

The supply conductors and the protective braiding on the heating tape are connected to the PLEXO P in conformance to the installation instructions (in compliance with the relevant standards EN 60079-0 and EN 60079-7).

2. Technical data

Rated voltage
110 to 120 V or 208 to 254 V

Rated current
max. 20 A

Referenced rated capacity
max. 33 W/m at 10°C

Explosion protection

Ex protection type
 Ⓜ II 2G Ex e II T5, T6
 Ⓜ II 2D Ex tD A21 IP65 T 95 °C, T 80 °C

Certification
 KEMA 08 ATEX 0111
 IECEx KEM 09.0084

Conformity to standards:
 EN 60079-0: 2006, EN 60079-7: 2007, EN 61241-0: 2006,
 EN 61241-1: 2004, EN 60079-30-1: 2007
 IEC 60079-0:2004, IEC 60079-7:2006, IEC 61241-0:2004,
 IEC 61241-1:2004, IEC 60079-30-1:2007

Minimum bending radius
25 mm

Max. permissible process temperature
 (applies to heating tape with remote end termination)
 +65°C when the heating tape is switched on
 +85°C when the heating tape is switched off

Ambient temperature range
-50°C to +65°C

Min. cut-in temperature
-40 °C

3. Safety Instructions

The relevant installation and operating regulations must be observed for electrical systems in hazardous areas (e.g. Directive 1999/92/EC, Directive 94/9EC, EN 60079-14, EN 61241-14 and the DIN VDE 0100 series).

The requirements under EN 60519-1 and EN 60519-2 on safety in electroheat installations must be complied with.

Thermal Safety Class 0 under EN 60519-2 Section 13 is met by the heating tape's design characteristics.

The Cu braid with a resistance of < 18.2 Ω/Km is suitable as a protective conductor.

To protect against indirect contact, conductive parts from other firms must be included in the (protective conductor) safety measures. For each electric circuit it is necessary to have a residual-current circuit-breaker and a means of isolating all outer wires from the current supply.

The operator of an electrical system in a hazardous environment has to keep the equipment in an orderly condition, operate it correctly, monitor it and do the required maintenance and repairs.

(EN 60079-14, EN 60079-17, EN 60079-19 and EN 61241-14).

4. Assembly of heating circuits

The specifications in the EC Type Examination Certificate and in the installation instructions must be observed. The data in Installation Instruction for the heating tape must be observed also.

Do not connect the heating tape's two supply wires – short circuit!

5.a) Assembly

The relevant installation and operating regulations must be observed when setting up or operating explosion-protected systems (e.g. EN60079-14, EN 60079-30-2 and the DIN VDE 0100 series).

The heating tape must be installed on the workpiece in accordance with the project engineering specifications. Only qualified specialists may do any of the work on the machine. Before any work is done on the machine, it must have come to a complete stop, be disconnected and precautions must be taken to ensure that it cannot be switched on again.

Before and during installation: keep the ends and connection components of the heating system dry. The metallic braiding in this heating system must be connected to a suitable earthing terminal.

!! The minimum bending radius must be observed.

The heating tape is attached to the workpiece by means of temperature-resistant adhesive tape with a max. spacing of 200 mm!! Use only plasticiser-free adhesive tapes (no PVC adhesive tapes)!

After every dismantling, replace the sealings for the heating tape and supply cable if there are any visible signs of permanent deformation.

To ensure efficient heat transmission, the heating tape must have even contact over the entire length of the surface. If necessary, the distances between fastenings must be reduced. The tape is laid on the pipelines either parallel to the axis of the pipe or in spiral form (in accordance with the project engineering instructions).

On plastic pipes, which conduct heat less efficiently than metal pipes do, aluminium foil or aluminium adhesive tape is put under or over the heating tape. This substantially improves the distribution of heat, prevents a local accumulation of heat and at the same time it partly compensates for the lower heat dissipation and associated reduction in the capacity of the heating tape. The PLEXO BP must be mounted onto an Ex e or Ex tD approved enclosure in a way that ensures that

the IP56 protection class will be upheld.

To connect the PLEXO P-CN, P-CW and P-CA to the voltage supply, it is necessary to use a supply cable, approved cable gland and approved junction box that suit the applications. The cable gland must be mounted onto the enclosure in a way that ensures that the IP65 protection class will be preserved. The protection rating conforms to EN 60529.

Once the heating system with accessories has been mounted, the insulation resistance between the heating conductor and the metallic braid must be verified.

The testing voltage should be at least 500VDC and the insulation resistance at least 20 MΩ/km EN 60079-30-2 Section 8.3.4)

When used in TT and TN systems a residual current device according to IEC 60079-30-1, clause 4.3 point d) shall be installed. When used in IT systems an insulation monitoring device according to IEC 60079-30-1, clause 4.3 point e) shall be used.

Caution! When mounting the PLEXO P with cold-applied connection technology, observe the operating instructions for the 27-1680-***10/**** heating system.

5.b) Commissioning

The equipment may only be operated if it is clean and free of any

damage. Electrical systems must be examined by an electrician before commissioning and afterwards at certain intervals of time.

6. Operation, maintenance and fault clearance

The heating systems must be used only in accordance with their intended purpose and within the operating data specified by BARTEC. The operator of an electrical system in a hazardous environment must keep it in good condition, operate it properly, monitor it and do maintenance and repairs. (EN 60079-14, 61241-14).

Caution! When mounting the PLEXO P with cold-applied connection technology, observe the technical data for the 27-1680-***10/**** heating system.

Only an electrician may do the maintenance work and fault clearance. Before restarting operation, check compliance with the applicable laws and directives. Before maintenance or troubleshooting, make sure that the specified safety regulations are adhered to.

Warning! DO NOT OPEN WHEN ENERGIZED

PLEXO B-P:

Warning! POTENTIAL ELECTROSTATIC CHARGING HAZARD - SEE INSTRUCTIONS

Clean the protective tube with a damp cloth only!

7. Accessories, spare parts see BARTEC catalogue.

Maximum length of heating circuit (according to the dimensioning of the capacity circuit breaker, characteristic C)

Type	°C	W/m	Rated voltage AC 120 V		Rated voltage AC 240 V	
			16 A	20 A	16 A	20 A
PSB 10 07-5801-.10.	+10	10	95	95	205	205
	-15		69	90	139	186
	-30		58	75	120	150
PSB 13 07-5801-.13.	+10	13	78	86	169	179
	-15		55	72	111	149
	-30		47	59	94	124
PSB 15 07-5801-.15.	+10	15	67	80	145	16
	-15		45	60	93	125
	-30		39	49	77	106
PSB 20 07-5801-.20.	+10	20	58	70	116	140
	-15		37	46	72	93
	-30		30	38	55	77
PSB 25 07-5801-.25.	+10	25	43	58	88	117
	-15		30	38	58	75
	-30		26	31	45	64
PSB 33 07-5801-.33.	+10	33	33	45	70	90
	-15		25	32	49	64
	-30		21	26	43	52

Reservation

Technical data subject to change without notice. Changes, errors and misprints may not be used as a basis for any claim for damages. 2

8. Type label heating system

The type label is to be filled in manually on the basis of the table and points 1-6. The blanks in the heating system's type number must be filled on the basis of the components used. A water-proof and lightfast marker must be used (e.g.: Staedtler Lumocolor permanent special marker or BARTEC no.: 02-7140-0001).

The serial no.: and the TAG no. can be filled in by the person setting up the heating-circuit.

A practical example of a filled-in type label is given further on. The type label must be stuck onto the lid of the junction box. The surface must be cleaned first before the glue is applied. Care must be taken that the sticker is put on carefully. It may not jut out over the correct area and it may not have any air bubbles.

Practical example:

The following components were used:
PSB 120 V 26 W; PLEXO P and BARTEC polyester junction box.
It was filled in according to the grey-shaded line in the table.

new Declaration of Conformity

Table

Typ heat trace	Supply voltage	Supply voltage ④	T-class ①	T-class ②
07-5801-110 *	120 V	impressed voltage	T5	T95 °C
07-5801-113 *	120 V		T5	T95 °C
07-5801-115 *	120 V		T5	T95 °C
07-5801-126 *	120 V		T5	T95 °C
07-5801-133 *	120 V		T5	T95 °C
07-5801-210 *	254 V		T6	T80 °C
07-5801-213 *	254 V		T6	T80 °C
07-5801-215 *	254 V		T6	T80 °C
07-5801-226 *	254 V		T5	T95 °C
07-5801-233 *	254 V		T5	T95 °C

- ③ Protection device: 16 A, 20 A
- ⑤ Frequency: 50 oder 60 Hz
- ⑥ Construction week/year: 43/2009 (for example)

Reservation

Technical data subject to change without notice. Changes, errors and misprints may not be used as a basis for any claim for damages.



Individual parts	PLEXO						
	P-CA	P-CN	P-CW	B-P	P-S	P-1S	P-2S
1	■	■	■	■	■		
2	■	■	■		■	■	■
3	■	■	■	■	■ x 2		■
4	■	■	■	■	■		
5					■		
6		■	■				■
7		■	■				
8	■						
9	■						
10	■						
11	■						
12						■	
13						■	
14							■
15				■			
16				■			
17				■			
18	■	■	■	■	■	■	■
19	■	■	■	■	■	■	■
20	■	■	■		■		

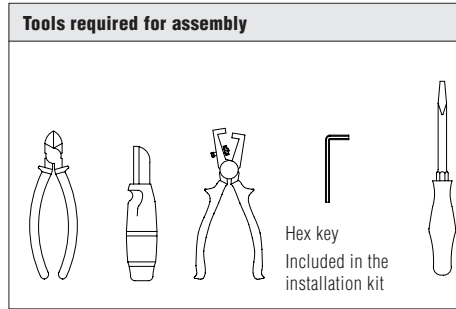

Examples of installation

PLEXO assembly on pipe

min. 50 mm Fastening area min. 50 mm

Fastening area min. 50 mm

Heating tape and supply cables

PSB self-limiting parallel heating tape

Protective sheath Metal jacking Insulating sleeve
Supply conductor

Supply cable to be used
for CN sleeve diameter 6 to 10 mm,
CW sleeve diameter 8 to 12 mm

Conductor Core Sheath

See certification for minimum requirements.

Supply cable to be used
for CA sleeve diameter 12 to 16 mm

Conductor Cores Core sleeve Reinforcement Sheath

See certification for minimum requirements.

Assembly at heating tape side

Heating tape side 1
P-CA, P-CN, P-CW, B-P, P-S

Cut off the heating tape with a **straight cut**.
Push sleeve **1** and clamping sleeve **3** over the heating tape.

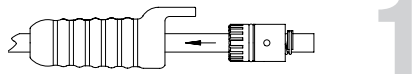

1

Remove 35 mm of the protective sheath from the heating tape.

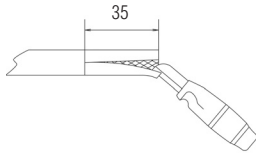

2

Push back the metal jacking. Expose 24 mm of the supply conductor.
The black heating element must be removed completely!
Cut out a triangle between the strands (5 mm)

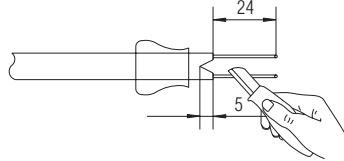

3

Bend the supply conductors slightly, twist and align them so that they are parallel again.

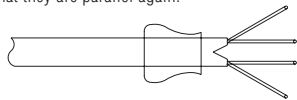

4

Move slide switch on plug 4 to „OFF“

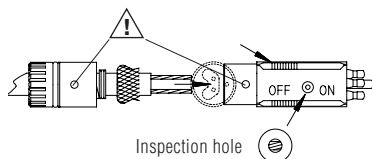

5

Feed the supply conductors into the plug and move the slide switch to the „ON“ position.
Supply conductors must be visible in the inspection hole!

Push the clamping sleeve **3** onto plug **4** until the locking pin snaps into the borehole.

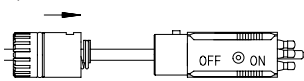

6

Heating tape side 2
P-S, P-2S

Cut off the heating tape with a **straight cut**.
Push sleeve **2** and clamping sleeve **3** over the heating tape.

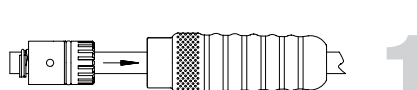

1

Move the slide switch on socket **5** to „OFF“.
Feed the supply conductor into the socket and move the slide switch to the „ON“ position.
Supply conductors must be visible in the inspection hole!

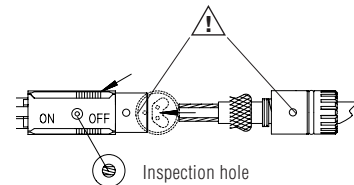

2

Push clamping sleeve **3** onto socket **5** until the locking pin snaps into the borehole.

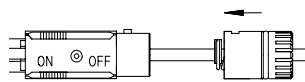

3

Assembly supply cable side

Supply cable side
P-S, P-CW

Push sleeve **2** and clamping sleeve **7** onto supply cable.

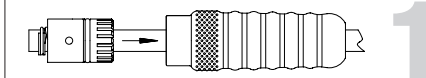

1

Remove 20 mm of the sheath off the supply cable.
Strip 8 mm of the core insulation.

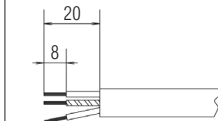

2

Twist and align conductors

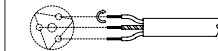

3

Move the slide switch on socket **6** to „OFF“

Feed the three conductors into the socket simultaneously and move the slide switches into the „ON“ position.

Attention: the protective earthing conductor must be connected to the terminal point marked green. Supply conductors must be visible in the inspection hole!

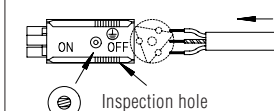

4

Push clamping sleeve **7** onto socket **6**. **The clamping sleeve must lie flush!** Tighten the strain relief screw until the supply cable is clamped securely.



5

Armoured supply cable side
P-CA

Remove 52 mm of the sheath from the supply cable. Remove 28 mm of the armouring. Strip 6 mm of the core insulation.

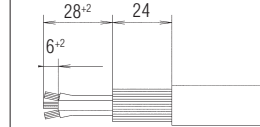

1

Make sure the clamping rings are tapered!

Push the outside clamping ring **9** over the reinforcement. Push the inside locking **8** under the reinforcement until it is flush with the reinforcement. Push the outside clamping ring as far as possible over the inside clamping ring and push the reinforcement forwards.

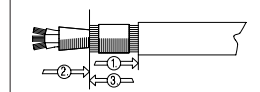

2

Push sleeve **2** and clamping sleeve **10** onto the supply cable.

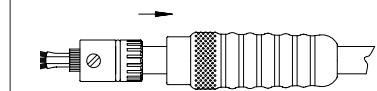

3

Align the conductors.

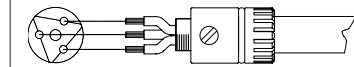

4

Move the slide switch on socket **11** to „OFF“

Feed the three conductors into the socket simultaneously and move the slide switch to the „ON“ position.

Attention: the protective earthing conductor must be connected to the terminal point marked green. Supply conductors must be visible in the inspection hole!

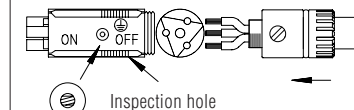

5

Push the clamping sleeve **10** onto socket **11**. Tighten the strain relief screw until the supply cable is clamped securely.

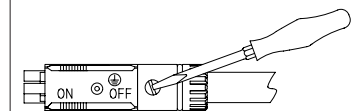

6

Reservation

Technical data subject to change without notice. Changes, errors and misprints may not be used as a basis for any claim for damages.

Assembly heating tape end

P-1S

Cut off the heating tape with a **straight cut**. Push sleeve **2** and clamping sleeve **13** over the heating tape.

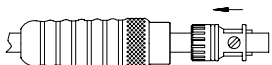

1

Remove 15 mm of the protective sheath from the heating tape.

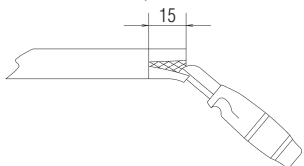

2

Remove the metal jacking with a diagonal cutter or knife. Cut out a triangle between the strands (5 mm)

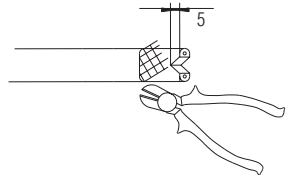

3

Position clamping sleeve **13** 40mm from the end of the heating tape. Tighten the strain relief screw until it clamps the heating tape securely.

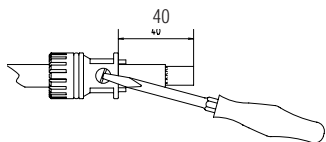

4

Push end sleeve **12** onto the end of the heating tape up to clamping sleeve **13**.

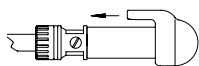

5

Twist end sleeve **12** onto sleeve **2**. Use hex key **18** to tighten the grub screw in the ridge on the sleeve.

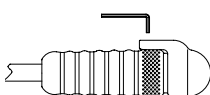

6

Final assembly

Heating tape joining and connection

P-CA, P-CN, P-CW

Join the plug and socket together. The pin and hole must be aligned one over the other. Green covers are opposite each other.

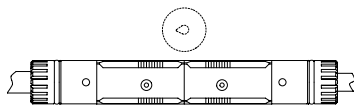

1

Bring the sleeves together and screw them one to the other. Use hex key **18** to tighten the grub screw in the ridge on the sleeve.

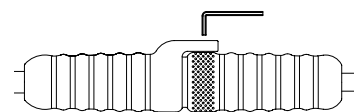

2

Heating tape end

P-2S

Push the sleeve over clamping sleeve and socket. Screw on the end sleeve. Use hex key **18** to tighten the grub screw in the ridge on the sleeve.

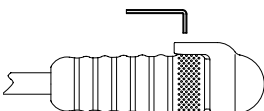

Cable ties

Fasten the cable ties **19** with the imprint „**WARNING - disconnect from voltage before opening**“ after the final assembly on the PLEXO. Preferably over the ridge.



Cable gland

Screw cable gland **20** into the enclosure.

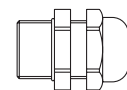

Mounting direct enclosure entry side B-P

Screw in the direct enclosure entry **15** into the junction box. Use the hexagon nut **17** for locking purposes inside the enclosure.

Clamp the black cores on L and N and clamp the green/yellow cores on PE.

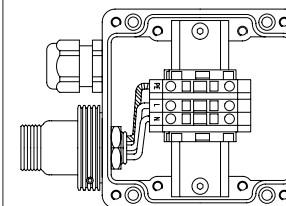

1

Join the plug to the socket in the direct enclosure entry **15**. Pin and hole must be aligned one on top of the other.

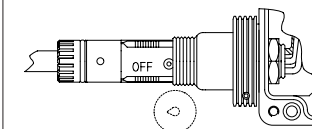

2

Bring sleeve **1** and the direct enclosure entry **15** together and screw them together. Use hex key **18** to tighten the grub screw in the ridge on the sleeve.

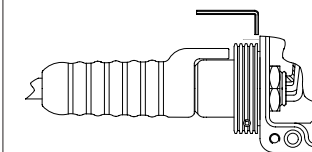

3

Push the protective pipe **16** onto direct enclosure entry **15**. A borehole in the protective tube must be brought into alignment over one of the two grub screws on the direct enclosure entry. Use hex key **18** to unscrew the grub screw until the protective tube is locked in place.

The grub screw may not jut out over the tube diameter

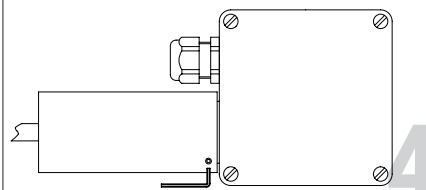

4

Reservation

Technical data subject to change without notice. Changes, errors and misprints may not be used as a basis for any claim for damages. 10