

Table of contents:

- 1. Connection examples for keyboard wedge:
 - 1.1 Keyboard wedge connected to supply unit with RS232 interface:
 - 1.2 Keyboard wedge connected to supply unit with TTY interface:
 - 1.3 Hand scanner connected to remote station:

- 2. Programming the BCS 302^{ex} Hand Scanner:
 - 2.1 Components required:
 - 2.2 Required barcodes in the manual:

- 3. Instructions for programming the BCS 302^{ex} hand scanner:

- 4. Instructions for programming the keyboard wedge:
 - 4.1 Setting the keyboard wedge mode (ID number):
 - 4.2 Programming the emulation of function keys and the full ASCII emulation:
 - 4.3 End of Message Character:
 - 4.4 Beep Sound:

1. Connection examples for keyboard wedge:

1.1 Keyboard wedge connected to supply unit with RS232 interface:

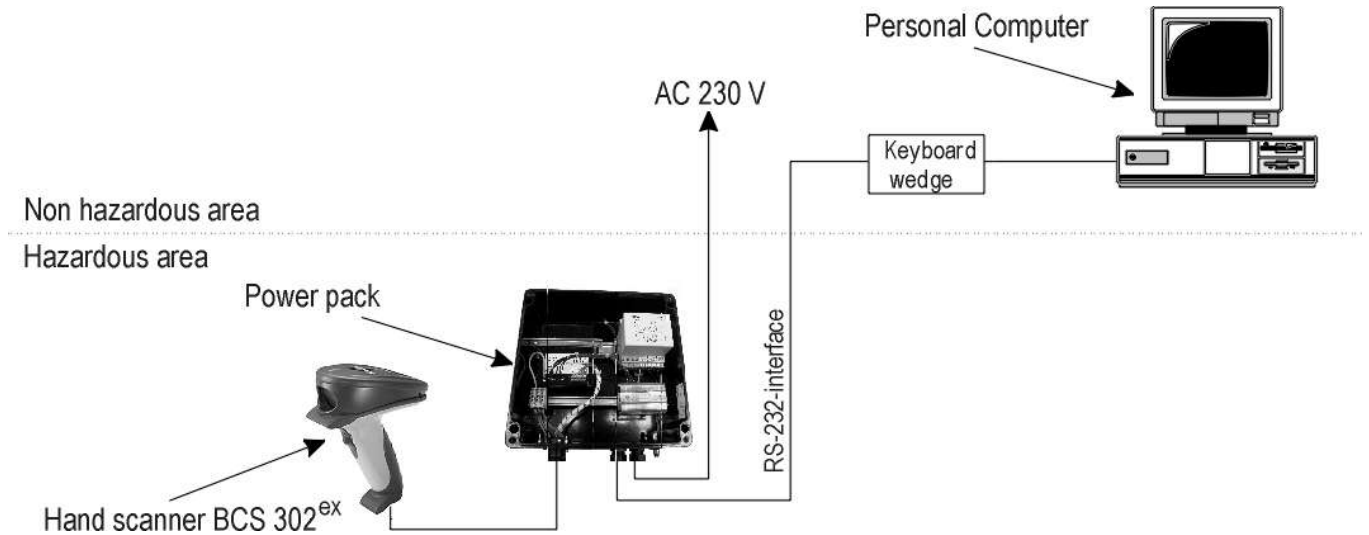

Wiring diagram for supply unit, type 17-21BB-0218 (RS-232 interface)

For supply of Hand Scanner BCS 302^{ex} Type 17-21BA-0020

X1	Serial interface RS232	1	TxD
		2	Gnd
		3	
		4	
X2	Supply voltage AC 100 V – 250 V	1	L
		2	N
		PE	PE

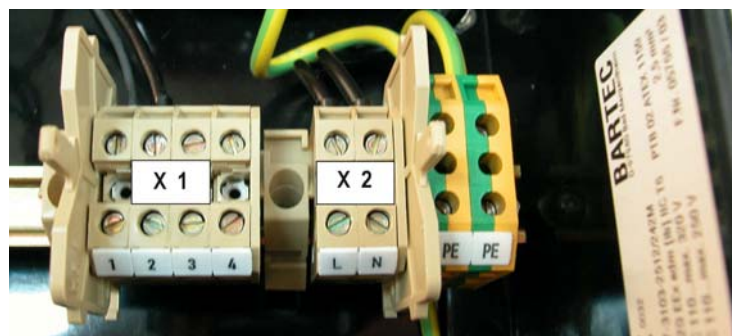

**Wiring diagram for keyboard wedge Master BB+, type 17-28BE-0001,
connected to supply unit with RS232 interface**

Pin connections of the RS232 interface of the supply unit and the RS232 interface of the keyboard wedge Master BB+.

Power pack for the hand scanners BCS 302 ^{ex}		Keyboardwedge 9 pin Sub D	
1	TxD	4	RxD
2	Gnd	7	Gnd
3			
4			

1.2 Keyboard wedge connected to supply unit with TTY interface:

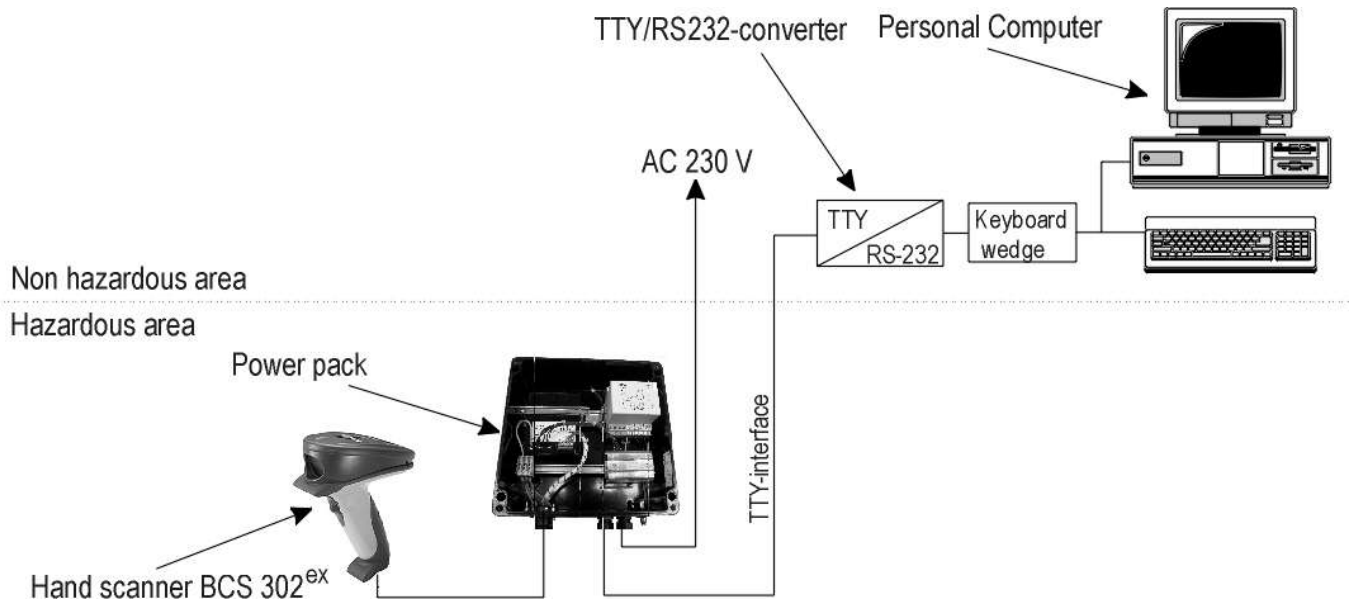

Wiring diagram for supply unit, type 17-21BB-0217 (TTY interface)

For supply of Hand Scanner BCS 302^{ex} Type 17-21BA-0020

X1	Serielle Schnittstelle TTY	1	20 mA
		2	Kollektor
		3	Emitter
		4	Gnd
X2	Spannungsversorgung AC 250 V	1	L
		2	N
		PE	PE

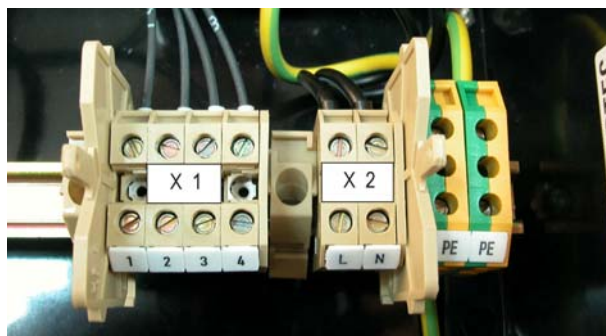

**Wiring diagram for keyboard wedge Master BB+, type 17-28BE-0001,
and TTY-/RS-232 transducer, type 17-28BE-0000,
connected to supply unit with TTY interface**

Pin connections of the TTY interface of the supply unit and the TTY interface of the TTY-RS-232 transducer from Phoenix Contact.

Power pack for the hand scanners BCS 302 ^{ex}		TTY-/RS-232-Converter	
1			
2	TxD+	24	RxD+
3	TxD-	25	RxD-
4			

Pin connections of the RS-232 interface of the TTY-/RS-232 transducer from Phoenix Contact and the RS-232 interface of the keyboard wedge Master BB+.

TTY-/RS-232-Converter		Keyboardwedge 9 pin Sub D	
2	(TxD)	4	(RxD)
3	(RxD)	3	(TxD)
7	(Gnd)	7	(Gnd)

1.3 Hand scanner connected to remote station:

Keyboard wedge connected to supply unit with RS232 interface:

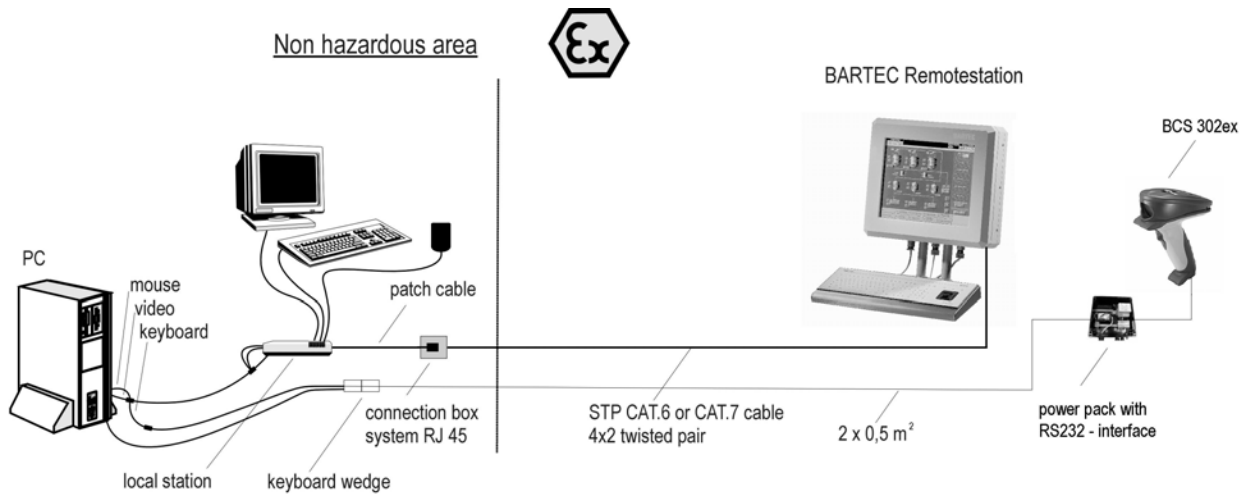

Keyboard wedge connected to supply unit with TTY interface:

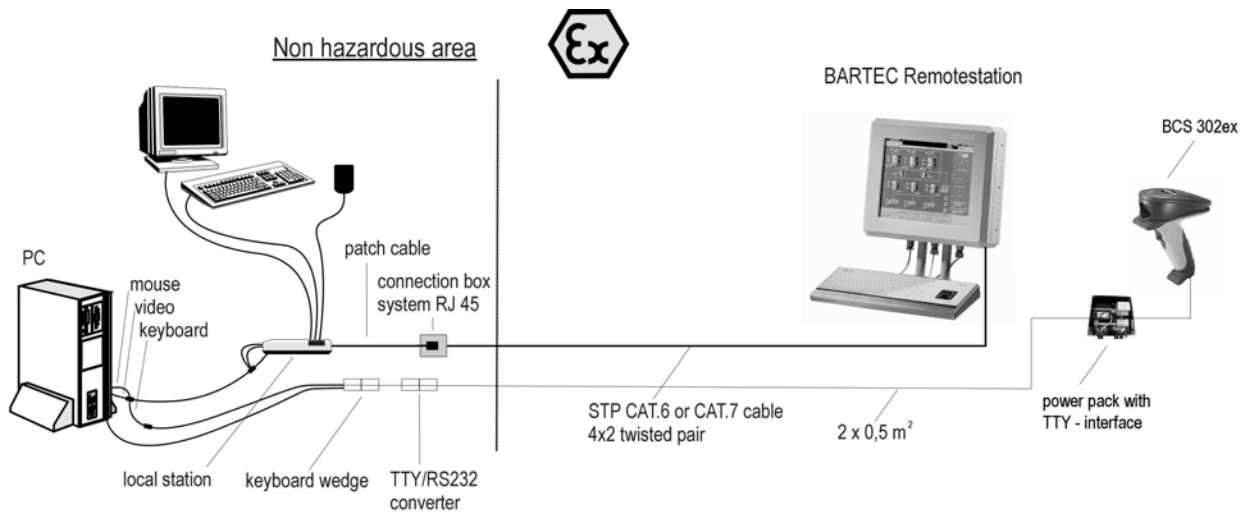

2. Programming the BCS 302^{ex} Hand Scanner:

2.1 Components required:

- Instruction manual from Symbol for programming (product reference guide for P300 STD/FZY/PRO scanner)
- BCS 302^{ex} Hand Scanner
- Keyboard wedge Master BB+ with instruction manual
- Ready-connected and operative system

2.2 Required barcodes in the manual:

- Page 2 – 9 Barcode **Set All Defaults**
- Page 2 – 12 Barcode **Standard RS – 232 C**
- Page 2 – 16 Barcode **Continuous On**
- Page 2 – 50 Barcode **Enable Code 39**
- Page 2 – 96 Barcodes **Scan Suffix** or **Data Format Cancel** (if incorrectly scanned)
- Page 2 – 120 for **Numeric Barcodes (7013 for Enter character)**
- Page A – 6 for selection of **Prefix Suffix Values**
- Page 2 – 97 Barcodes **Scan Options** and **<Data> <Suffix>**
- Page 2 – 98 Barcodes **Enter**
- Page 2 – 101 Barcode (Parity) **Even**
- Page 2 – 108 Barcode (ASCII Format) **7 – Bit**

3. Instructions for programming the BCS 302^{ex} hand scanner:



Set All Defaults
Standard settings



Standard RS-232C

Baud Rate = 9600, Parity = None, Hardware and Software Handshaking = None, Stop Bit = 1 and ASCII Format = 8 - Bit



Continuous On: After scanning a barcode the scanner is still live. If no scanning takes place for 60 minutes the hand scanner goes over to the standby mode.



Enable Code 39



Scan Suffix

Enter symbol as suffix programming

Enter = 7013



7



0



1



3



Scan Options



<Data> <Suffix>



Enter

Completes programming of the suffix for the keyboard wedge



ASCII Format 7 – Bit

Setting is required for the wedge.



Parity = Even

Setting is required for the wedge.

4. Instructions for programming the keyboard wedge:

Please note: When scanning the barcode make a pause of approx. 1 sec.

4.1 Setting the keyboard wedge mode (ID number):

ID Information	Germany:
104	Supports emulation of function keys
114	No emulation of function keys
ID Information	USA:
011	US keyboard with emulation of function keys
ID Information	Belgium:
644	No emulation of function keys (use of DELL keyboard)
ID Information	France:
654	No emulation of function keys

Further ID numbers are given in the connection list of the manufacturer PSC.

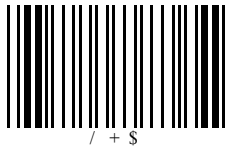

Default configuration of the keyboard wedge:

By reading in this barcode the keyboard wedge is returned to its standard setting.

After scanning, wait approx. 6 sec until acknowledged.



Configuration start: In order to programme the keyboard wedge this special start sequence must be scanned at the beginning.



Activation of the keyboard wedge mode

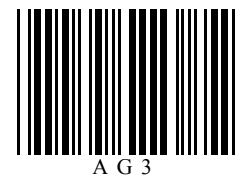
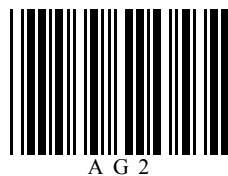

Since the keyboard wedge can be connected to almost all available PCs, the keyboard wedge must be programmed to the respective PC. For this purpose a so-called I.D. (three digit number) is required.



Through this barcode a deactivated upper-case key is assumed.

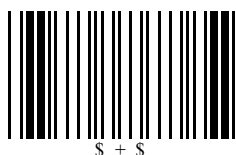

Configuration end: By scanning this barcode the alterations are stored.

4.2 Programming the emulation of function keys and the full ASCII emulation:

In order to use the function keys and the full ASCII code the following barcodes must be scanned in.

For activation: → **START** Emulation of function keys **ACTIVATED** →
 Full ASCII emulation **ACTIVATED** → **END**
 For deactivation: → **START** Emulation of function keys **NOT ACTIVATED** →
 Full ASCII emulation **NOT ACTIVATED** → **END**

START

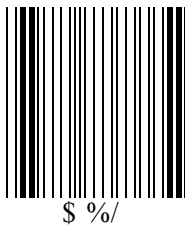

Emulation of function keys

NOT ACTIVATED

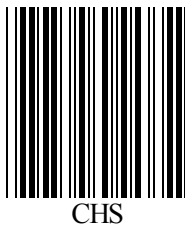

ACTIVATED



Full ASCII emulation

NOT ACTIVATED

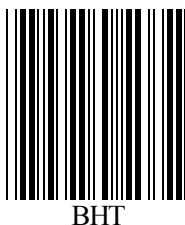

ACTIVATED



END

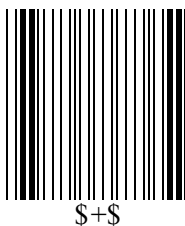

4.3 End of message character:

START

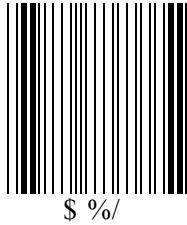

END



No character

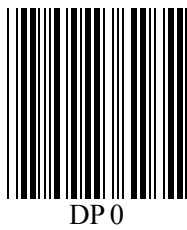

Field advance



TAB +

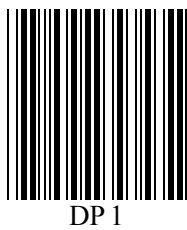

Enter



LF

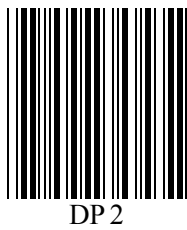

CR/LF, feed, send



Field exit

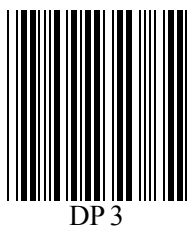

Return



4.4 Beep sound:

START



\$ %/

END



\$+\$

High beep

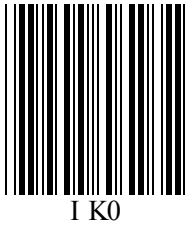

I K0

Low beep



I K1

Medium beep

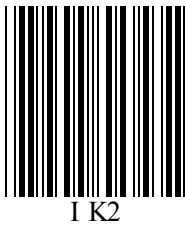

I K2

Beep OFF



I 00