

BARTEC

UNITA' DI CONTROLLO E COMANDO O
UNITA' DI INTERFACCIA (APPARECCHIATURE ASSOCIATE)

SERIE CCF... EJB...

GRUPPO II CATEGORIA 2(1)G o 2(1)GD

MODO DI PROTEZIONE EEx d [ia] IIB T6 o T5

IP66 o IP66/67 T85°C o T100°C

ISTRUZIONI DI SICUREZZA

Control and Command units or
Interface units (associated apparatus) series CCF... EJB...

Group II category 2(1)G or 2(1)GD

Protection mode EEx d [ia] IIB T6 or T5

IP66 or IP66/67 T85°C or T100°C

Safety instruction

IN ACCORDO ALLA DIRETTIVA 94/9/CE

According to directive 94/9/EC

PRODUCTION LOCATION: KEURMEESTERSTRAAT 17 – NL 2984 BA RIDDERKERK – NETHERLANDS

TEL. (+31) 180 410588 – FAX. (+31) 180 414134

<http://www.bartec.nl> – e-mail: info@bartec.nl

CONFORMITA' ALLE NORMATIVE STANDARD

CUSTODIE CCF... EJB...

COSTRUITE IN ACCORDO ALLE NORMATIVE EN50014, EN50018, EN50020, EN50281-1-1 ACCORDO ALLA DIRETTIVA 94/9/EC DEL 23 MARZO 1994.

CONFORMITY WITH STANDARDS

ENCLOSURES CCF... EJB...

Manufactured according to European standards EN50014, EN50018, EN50020, EN50281-1-1 according to the European Directive 94/9/EC of March 23, 1994.



ISTRUZIONI DI SICUREZZA

RIVOLTE A PERSONALE QUALIFICATO IN ACCORDO CON LE LEGGI NAZIONALI, INCLUSE LE RELATIVE NORME E, DOVE APPLICABILE, IN ACCORDO CON IEC 79.17 RIGUARDANTE LE APPARECCHIATURE ELETTRICHE PER ATMOSFERE POTENZIALMENTE ESPLOSIVE.

LE CUSTODIE NON DEVONO ESSERE INSTALLATE IN AREA PERICOLOSA ZONA 0.

DEVONO ESSERE RISPETTATI I DATI TECNICI INDICATI SULLE CUSTODIE.

NON SONO AMMESSE MODIFICHE AL PRODOTTO.

LE CUSTODIE POSSONO ESSERE INSTALLATE SOLO SE COMPLETAMENTE INTEGRE.

DEVONO ESSERE UTILIZZATE ESCLUSIVAMENTE PARTI DI RICAMBIO FONDISONZO.

LE OPERAZIONI DI MANUTENZIONE ORDINARIE E STRAORDINARIE DEVONO ESSERE EFFETTUATE SOLO DA ELETTRICISTI QUALIFICATI CON L'APPROVAZIONE DI PERSONALE "ESPERTO".

DEVONO ESSERE STRETTAMENTE OSSERVATE LE NORME NAZIONALI DI SICUREZZA E PREVENZIONE INFORTUNI, E LE PRESCRIZIONI INDICATE CON "⚠" NEL PRESENTE FASCICOLO TECNICO.

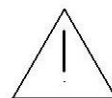

SAFETY INSTRUCTION

For skilled electricians and instructed personnel in accordance with national legislation, including the relevant standards and, where applicable, in accordance with IEC 79.17 on electrical apparatus for explosive atmosphere.

The boxes must not be operated in zone 0 hazardous areas.

The technical data indicated on boxes are to be observed.

Changes of the design and modifications to the equipments are not permitted.

The boxes shall be operated as intended and only in undamaged and perfect condition.

Only genuine FONDISONZO spare parts may be used for replacement.

Repairs may only be carried out by qualified electrician and will subsequently have to be checked by an "expert".

The national safety rules and regulations for prevention of accidents and the following safety instructions which are marked with an "⚠" in these operating instructions, will have to be observed.



**UNITA' COMANDO E CONTROLLO E INTERFACCIA
(APPARECCHIATURE ASSOCIATE) SERIE CCF.. EJB..
ISTRUZIONI DI SICUREZZA**

**Command and control units or interface units (associated apparatus)
Safety, maintenance and mounting instruction**

EXECUTION: EEx d [ia] IIB T6 FOR INTERFACE UNITS

EEx d [ia] IIB T6 OR T5 FOR CONTROL AND COMMAND UNITS

PROTECTION DEGREE: IP-65 FOR SILICON GREASE BETWEEN COVER AND BODY

IP-65 FOR GASKET BETWEEN COVER AND BODY

GROUP : II CATEGORY: 2(1)G OR 2(1)GD

INSTALLATION : ZONE 1, ZONE 2, ZONE 21, ZONE 22

AMBIENT TEMPERATURE: -20°C +40°C o -20°C +55°C

TEMPERATURE CLASS: T6 for amb. temp. -20°C +40°C or T5 for amb. temp. -20°C +55°C

MAX. SUPERFICIAL TEMPERATURE FOR DUST PROTECTION "D" o "GD" :
T85°C for temp. class T6 T100°C for temp. class T5

GENERAL ELECTRICAL CHARACTERISTICS:

NOM. VOLTAGE: 24 ÷ 1000 V ac 12 ÷ 250V dc

NOM. FREQUENCY: 50/60 Hz

MAX. CURRENT FOR FUSIBLES AND CONTACTS : 400 A

MAX. POWER FOR LAMPS: 5W per Tamb. -20°C +40°C 3W per Tamb. -20°C +55°C

ELECTRICAL CHARACTERISTICS FOR ASSOCIATED APPARATUS: Um ² 250 V

MAX OUTPUT DISSIPATED

The maximum power which can be dissipated inside the enclosure and the maximum current on contact and fuses are a function on enclosure size, of the temperature class (or of the maximum surface temperature for category GD units) and of the ambient temperature as specified in details in the following tables:

INTERNAL FLANGE	EXTERNAL FLANGE	MAXIMUM OUTPUT DISSIPATED IN WATT WITH AMBIENT TEMPERATURE OF 40° C		MAXIMUM OUTPUT DISSIPATED IN WATT WITH AMBIENT TEMPERATURE OF 55° C	
		CLASS T6 WITHOUT SIGNALLING LAMPS, ONLY SIGNALLING LED ARE ALLOWED	CLASS T5 WITH SIGNALLING LAMPS AND/OR SIGNALLING LED	CLASS T6 WITHOUT SIGNALLING LAMPS, ONLY SIGNALLING LED ARE ALLOWED	CLASS T5 WITH SIGNALLING LAMPS AND/OR SIGNALLING LED
CCF - 1	EJB - 1	45	45	34	34
CCF - 2	EJB - 2	60	60	45	45
CCF - 3	EJB - 3	75	75	56	56
CCF - 3B	EJB - 3B	55	55	40	40
CCF - 4	EJB - 4	100	100	75	75
CCF - 4B	EJB - 4B	75	75	56	56
	EJB - 45	140	140	105	105
	EJB - 45B	120	120	90	90
CCF - 5	EJB - 5	210	210	160	160
CCF - 5B	EJB - 5B	170	170	130	130
	EJB - 6	600	600	460	460
	EJB - 6B	490	490	370	370

The max permitted heat dissipation and characteristics for the EJB and CCF series enclosure depending must not exceed the above mentioned values when intrinsically safe devices having a maximum heat dissipation of 1.1Watts and non-intrinsically safe devices are mounted together. The maximum value of heat dissipation into the box includes also the maximum power dissipated of cables, terminals, and contacts. The values of the density current permitted into the boxes are foreseen by the Standard EN 60439-1. The prescriptions of this Standard must be respected during Design and Manufacturing of EJB... and CCFE... boxes.

USE AND MAINTENANCE

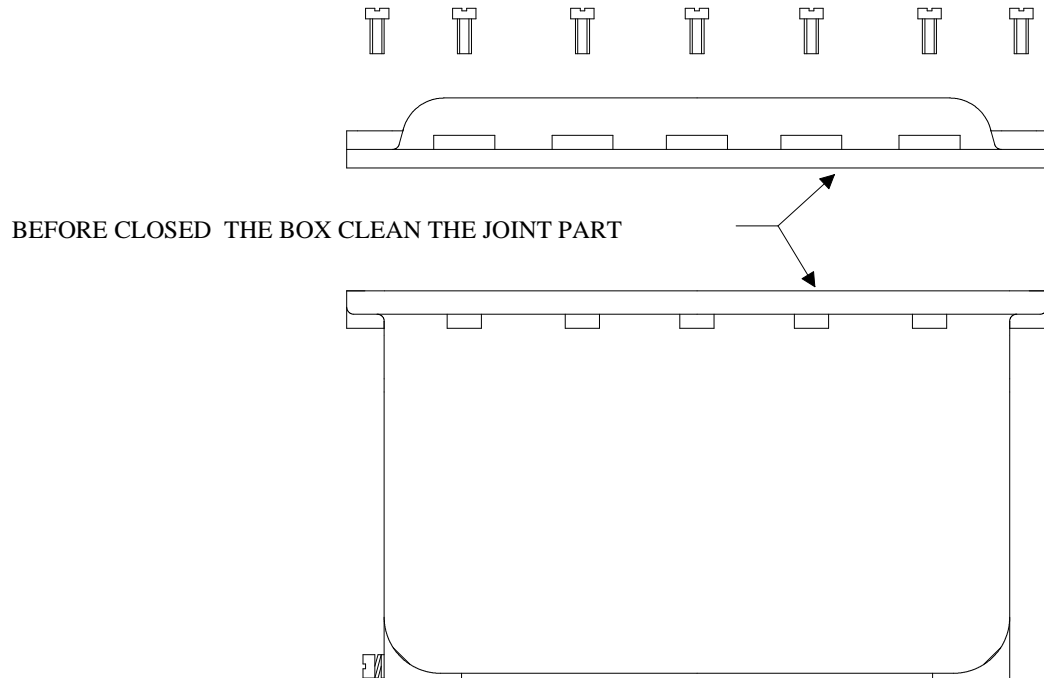

ALL OPERATIONS OF INSTALLATION, REPLACEMENT OR CONTROL MUST NOT BE PERFORMED WHEN CIRCUIT IS ALIVE.

MUST BE RESPECTED THE TECHNICAL DATA INDICATED ON TAG.

CLEAN AND LUBRICATE THE PART TO CONNECT:

WHEN GASKETS ARE USED TO MAINTAIN RAIN TIGHTNESS, BE SURE THE SAME ARE MOUNTED IN THEIR ADEQUATE LOCATIONS.

HANDLE CAREFULLY ALL JOINT PARTS SO TO AVOID DAMAGING COUPLING SURFACE.

ALL THE SPARE HOLES ON WALLS MUST BE CLOSED WITH CERTIFIED EEx d PLUGS.

THE SCREWS ON COVER ARE MADE IN STAINLESS STEEL QUALITY A2-70 ACCORDING TO UNI 7323 WITH A MAX. TENSILE STRESS OF 700 N/mm².

1) EXAMPLE FOR INTERFACE UNIT

EEx-i CONNECTION
TERMINALS

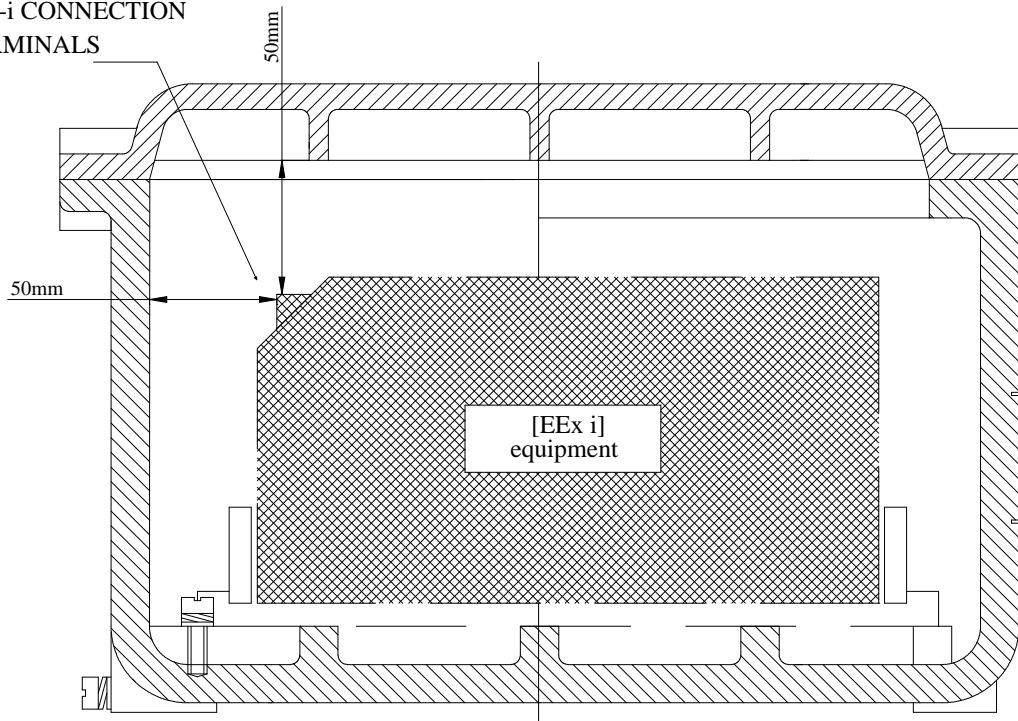

Types Of ACTIVE & PASSIVE Barriers Permissible for Installation inside the Enclosure

The active and passive (Zener) barriers utilised for installation inside the EJB and CCF series enclosures must possess their own individual ATEX generation certificate ("E" generation up to June 2003) according to Cenelec Norms EN50014 & EN50020 for Ex type of protection [Ex-ia] suitable for gas groups IIB & IIC and thus be marked as follows [EEx ia] IIB or IIC.

The characteristics and data of EEx-i circuits (U_o , I_o , P_o , C_o and L_o) are described on the device (certificate label), associated drawings for certification and the overall certificate for the EEx-i device. The maximum input voltage (U_m) of the barrier on the non Ex-i circuit must be < 250 volts.

Mounting details of Barriers inside EEx-d enclosures

The "OMEGA" guide as stated in EN50022 makes reference to the fixing of the active and passive (Zener) barriers inside an EEx-d enclosure.

The barriers are mounted as per the barrier manufacturers standard din rail having a maximum distance of 7.5mm between the device and depth of enclosure.

The barrier must be locked on the DIN rail via two earth terminals having a nominal cross section of 6 - 10sqmm or two end stops providing a mechanical protection as stated in the OMEGA guide EN50022.

The function and type of barrier determines the number of barriers installed inside the enclosure.

The maximum number must not exceed the value determined for each type of enclosure as detailed in drawing A1-4239 sheet 1 and 2.

Cable Terminations

The internal cable connections of the barrier refer to EN50022, which enables the barrier to possess a side of the device having an intrinsically safe circuit and the opposite side to have a non-intrinsically safe circuit as detailed below.

The internal cable connections to the intrinsically safe side of the device must be solely made with insulated conductors. The conductors must be fixed in such a way that they cannot be grouped, waved or placed directly next to conductors of non-intrinsically safe circuits

I.e Cables of non-IS circuits and IS circuits must be segregated.

The minimum distance between intrinsically safe and non-intrinsically safe conductors must be 8mm. The minimum grade of insulation for non-intrinsically safe conductors is >1.5KV and >0.5KV for intrinsically safe conductors.

Input & Output cables of the EEx-d Enclosure.

The input and output threaded cable entries of the EEx-d enclosure must be as per drawing

EE.222.1 (A1-4095) attached to certificate CESI 01 ATEX 004U.

The accessories (cable glands) used to terminate the cables to and from the enclosure shall be certified according to Norms EN 50014 and EN 50018.

Accessories tested in accordance with ATEX certificate may also be utilised.

To assure the Protection Degree the possible cable entries mounted on boxes must have, at least, the same protection degree of boxes.

The intrinsically safe cable(s) entering and exiting the enclosure must be clearly identified with a label, which is affixed to the enclosure wall with threaded rivets.

2) EXAMPLE FOR COMAND AND CONTROL UNITS (ASSOCIATED APPARATUS)

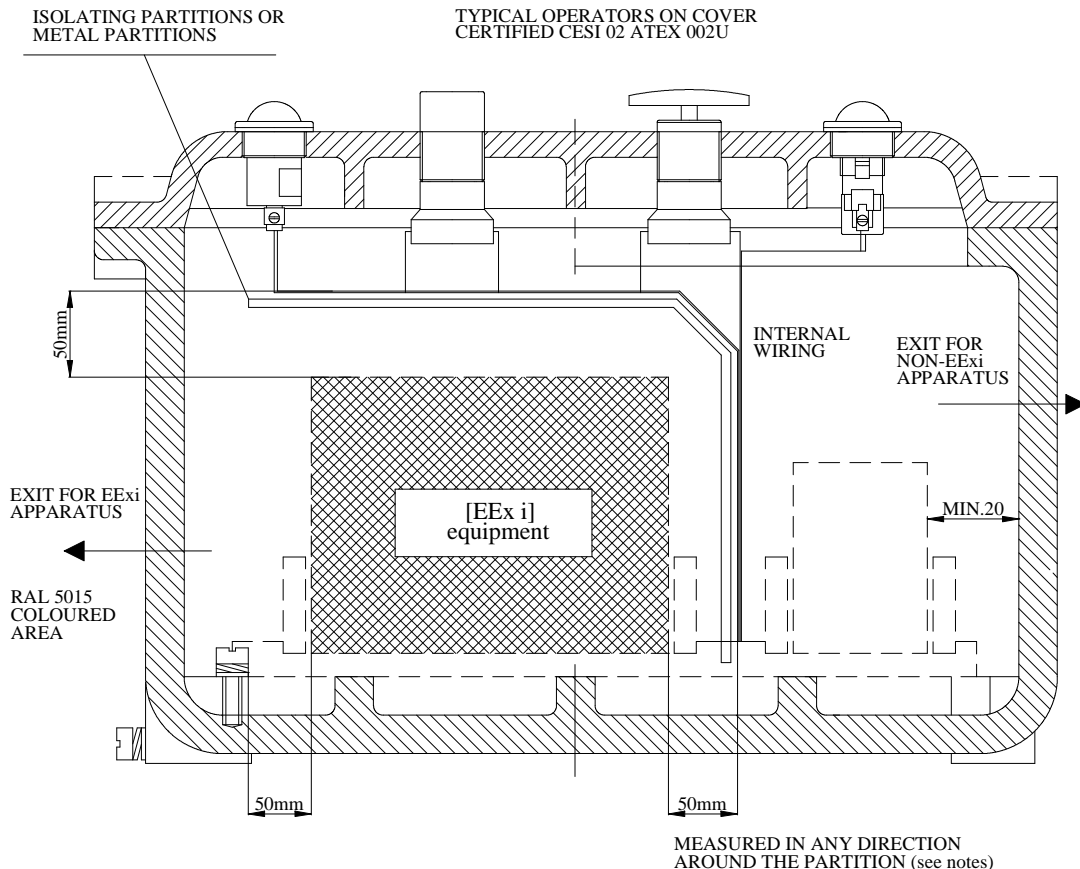

Installation of IS Devices and Non IS Devices inside and EEx-d enclosure

The Command, Control Units complete with accessories execution EEx d IIB can containing also Associated Apparatus [EEx ia] IIB/IIC In this case the execution shall be EEx d [ia] IIB.

The following rules for installation of IS equipment inside the EJB and CCF type enclosures must be adhered to.

When intrinsically safe devices are installed inside an enclosure together with non-intrinsically safe devices and components, a minimum of 50mm segregation must be maintained as detailed in drawing A1-4239

The intrinsically safe earth must be always be a clean earth and be totally insulated from the supply ground.

Mounting

All the Associated Apparatus are mounted on DIN rail. They can be mounted also on internal frame respecting the min. distances foreseen. The Apparatus mounted on DIN rail or mounted on internal frame must respect the same prescriptions.

Partitions used to separation

When separation is accomplished by partitions, they are accurately dimensioned, thickness of partition and fixing into box must be estimated, the partitions must be guaranteed the air circulation into boxes.

Incoming Cables

The incoming cables for EEx-i connections are marked with a label, or the area is painted with blue colour RAL 5015. To assure the execution and the protection degree of construction, the cable entries mounted on boxes must have, at least, the same protection degree of boxes.

Internal wiring

The cable passages of EExi cables are manufactured and identified with one of the following methods:

- Cables with isolating colour light blue (if into housing are not other cables with this colour).
- Separation of cables EExi and cables non-EExi with cable tray painting in light blue
- Grouping the EExi cables with electric tape (or similar) and identify the area of a label (colour light blue) with the writing "Warning EExi circuits".

The section of cables for power circuits is min. 1.5 Sq.mm.

The distance between EExi circuits and non-EExi circuits is 50mm in all the directions.

The earth connection must be in accordance with EN 60079-14.

typical Disposition of internal Equipment

The number of equipment mounted inside the box are variable but according to some notes:

- The free area measured in any transversal section of box is min. 30%.
- The distance between equipment is adequate for the cable wiring

command control and signalling equipment

All the accessories series M... P... mounting on boxes are certified CESI 02 ATEX 002U. in this case the degree of protection is IP-66 with gasket between cover and body of box or IP-65 with silicon grease.

Any other type of accessories used, need to be ATEX certified, suitable for this application.